

Dimensiones

Susol

TS800

[mm]

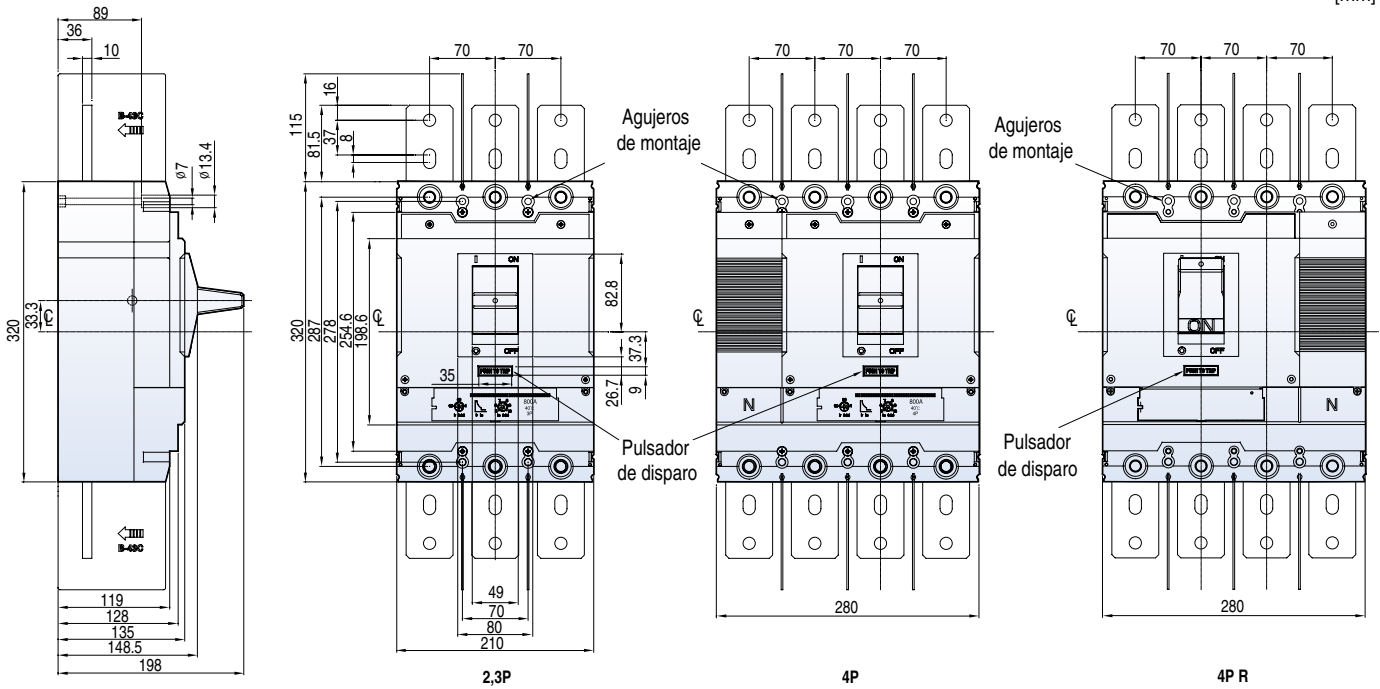

Seccion del terminal

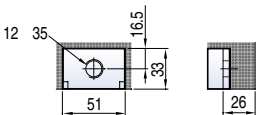

Conductor

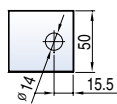

Perforacion del panel

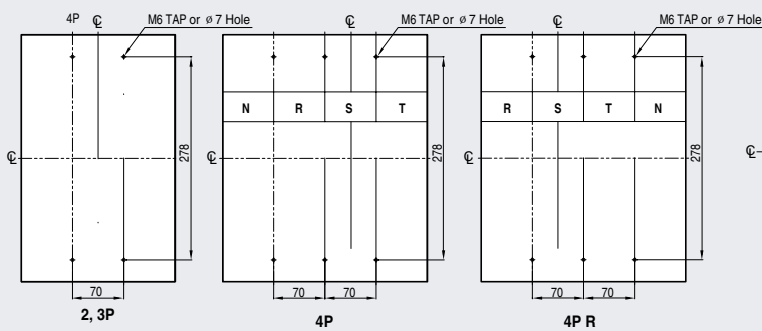

Corte frontal del panel

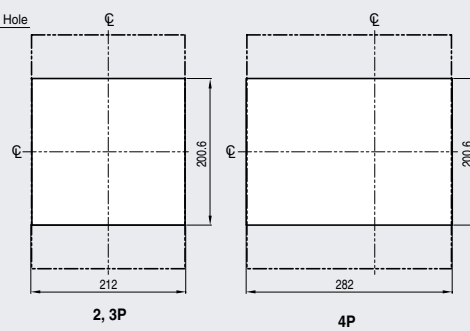

Accesorios para las series TD/TS hasta 800A

Susol

Diagrama

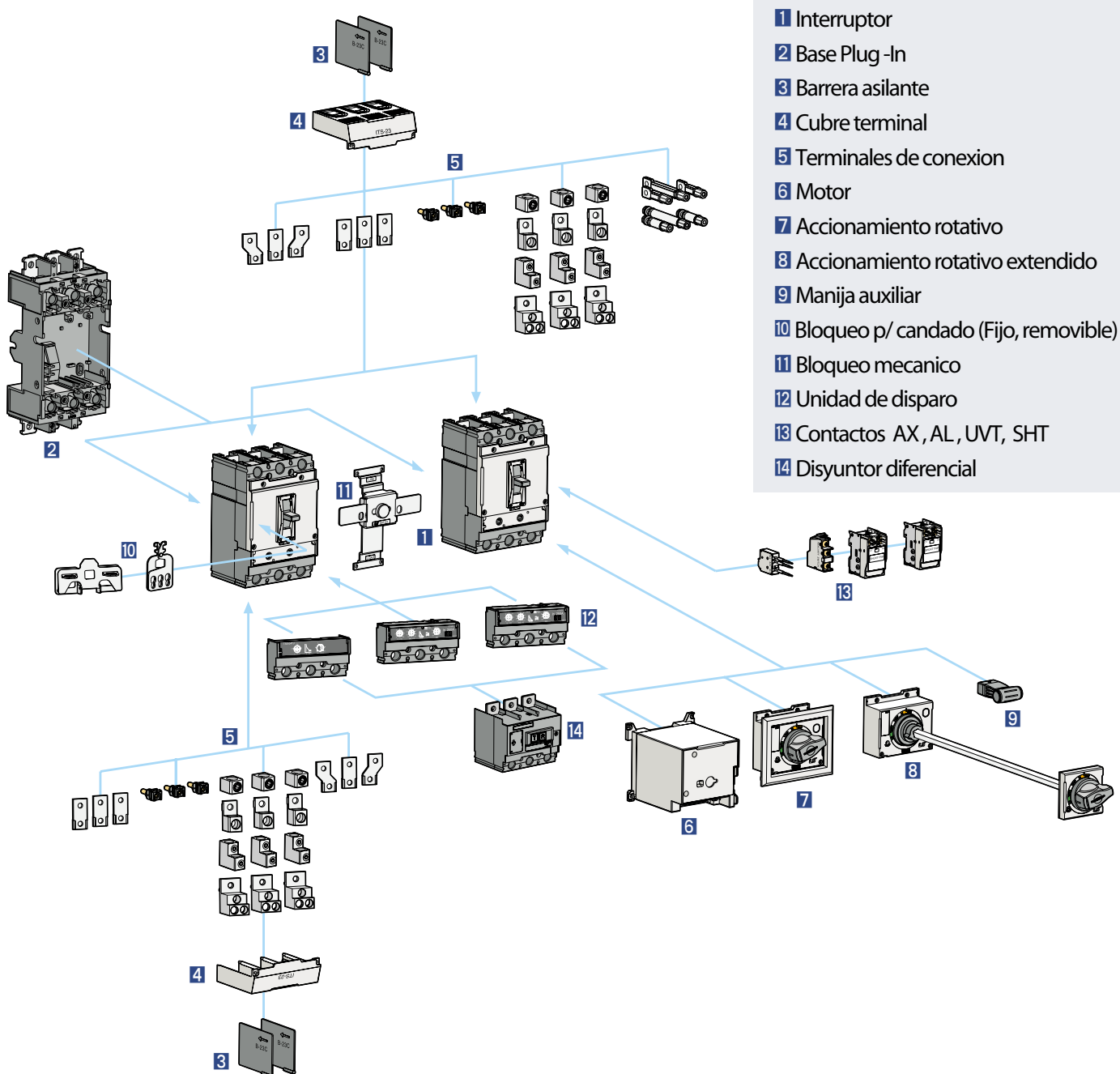

- 1 Interruptor
- 2 Base Plug-In
- 3 Barrera asilante
- 4 Cubre terminal
- 5 Terminales de conexión
- 6 Motor
- 7 Accionamiento rotativo
- 8 Accionamiento rotativo extendido
- 9 Manija auxiliar
- 10 Bloqueo p/ candado (Fijo, removible)
- 11 Bloqueo mecánico
- 12 Unidad de disparo
- 13 Contactos AX, AL, UVT, SHT
- 14 Disyuntor diferencial